

10.65 GAMA HEAVY DUTY

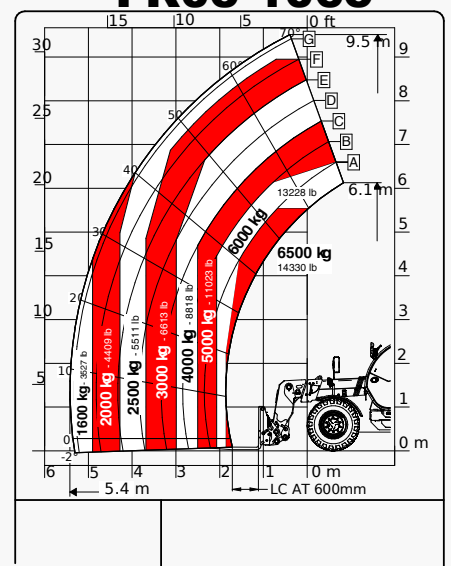

FR03-1065

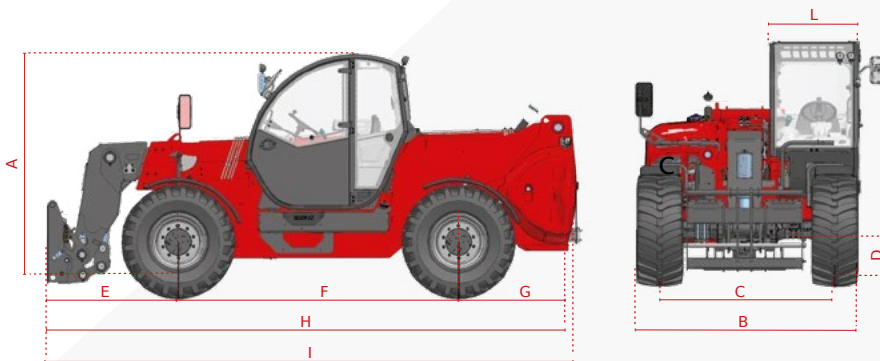

10.65 GAMA HEAVY DUTY

FISA TEHNICA

MODELE		10.65
DIMENSIUNI		
[A] Inaltime	mm	2550
[B] Latime	mm	2334
[C] Ecartament	mm	1840
[D] Garda la sol	mm	410
[E] Consola fata	mm	1673
[F] Ampatament	mm	2950
[G] Consola spate	mm	1265
[H] Lungime cu carlig	mm	5928
[I] Lungime fara carlig	mm	5856
[L] Latime cabina	mm	960
GABARIT		
Classic 74	Kg	11050
HLS 74	Kg	11200
VPSse 100	Kg	11250

MODELE		10.65
DETALII		
Numar sectiuni brat	nr	1
Capacitate maxima de ridicare	Kg	6500
Inaltime maxima de ridicare	m	9.5
Extensie maxima brat	m	5.4
Extensie brat la inaltime maxima	m	0.45
Unghi de basculare	°	149
CAPACITATE REZERVOR		
Rezervor hidraulic	litri	150
Rezervor carburant	litri	120
TIP CUPLARE BRAT		
FH HEAVY		°

NOTA: Dimensiuni definite pentru echiparea cu roti 445/65 R22,5

CONFIGURATII	CLASSIC 74	HLS 74	VPSse 100
TRANSMISIE			
Hidrostatica	2 game	2 game	CVT
Viteza	Km/h	40	40
MOTOR STAGIUL IV FINAL			
Marca	Deutz	Deutz	Deutz
Putere	kW/hp	74,4/101	100/136
Sistem catalizare	DOC + DPF + SCR	DOC + DPF + SCR	DOC + DPF + SCR
Fora de tractiune	daN	8500	10400
HIDRAULICA			
Tip pompa	rotativa	LS cu piston	LS cu piston
Debit hidraulic/presiune	litri/bar	120/230	180/250
ROTI			
445/65 R22,5	°	°	°
Raza de virare	m	4.5	4.5
ALTELE			
Joystick	mecanic-electro proportional	hidraulic-electro proportional	hidraulic-electro proportional
Cuplare rapida	°	°	°
Conexiune hidraulica spate dubla electro-proportionala	°	°	°
Lumini fata/spate LED	°	°	°
Conexiune electrica spate	°	°	°
Carlig de remorcare fix 6 t	°	°	°
Preincalzire bloc motor	°	°	°
Aer conditionat	°	°	°
Valva regenerare	-	°	°
Brat flotant	°	°	°
Suspensie brat	°	°	°
Separator de flux hidraulic cu 6 canale	°	°	°
PEB (Cupla electrica brat)	°	°	°
Super-reductor	°	°	°
Motor hidraulic	°	°	°
Mod cupa	°	°	°
Sistem de franare pentru remorca pneumatic/hidraulic	°	°	°
Echilibrare laterala ±10°	°	°	°

° Standard ° Optional Indisponibil